

# P270

## BOTTOM LOAD CASEPACKER

Servo bottom load casepacker provides efficient product handling while meeting all sanitary and FDA validation requirements



- All Servo Driven
- Balcony Design
- Compact Footprint
- All Belt Drives - low noise, longer life
- Unique Positive Dual Vacuum Case Erector
- Fast and Accurate Changeover - less than 5 minutes
- Efficient Product Collation/Accumulation
- Large Capacity, Ergonomic Case Magazine
- Low Maintenance - easy access to all components provides for easy maintenance
- User Friendly - fewer parts to time in
- Hot Glue or Tape Sealing
- **Validation Made Easy**

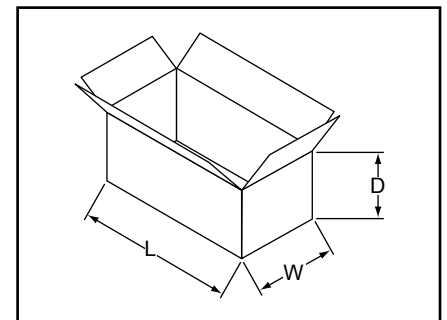

Case Range	Length	Width	Depth
Minimum	8" 203.2 mm	6" 152.4 mm	4" 101.6 mm
Maximum	24" 609.6 mm	15" 381 mm	12" 304.8 mm

Larger Ranges Available

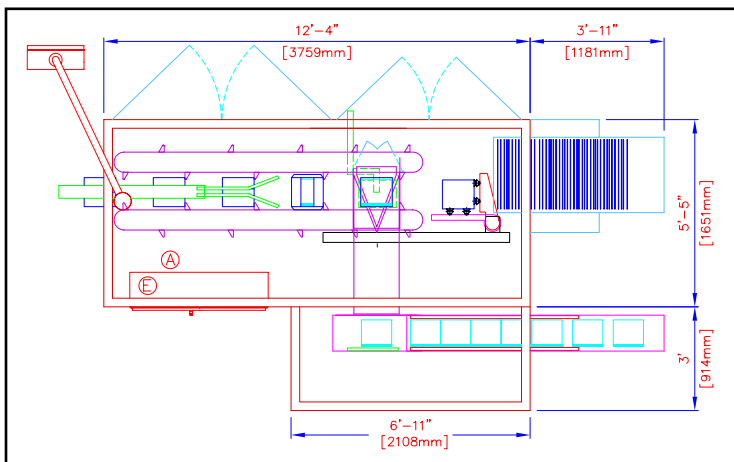

Standard Range Floorplan

**SERPA**  
**PACKAGING SOLUTIONS**  
 7020 W. Sunnyview Ave. • Visalia, CA 93291  
 TEL: 559.651.2339 • FAX: 559.651.2345  
 sales@serpapakaging.com  
 www.serpapakaging.com